



Type(s)  
Project  
Date  
Notes

**GENERAL INFORMATION**

ETC’s Selador Desire D22 luminaire puts the x7 Color System into a compact, round washlight. Highly efficient primary lenses and careful color choices make the D22 fixture ideal for stage, studio, architecture and anywhere vibrant color and high intensity are requirements. The x7 Color System produces the widest range of spectrally-balanced saturated and tinted color choices available, while the static-white options provide an impressive punch. D22’s rugged die-cast enclosure, noiseless fan-free operation, multiple lens options, convenient size and advanced user interface make it an ideal addition to the Desire family of LED luminaires.

**D22 LED Array**

D22 fixtures are available with any one of the following arrays (not interchangeable) to best suit the intended application.

- D22 Lustr+: Optimized array with six colors plus high-intensity white LEDs to create an ideal wash fixture for full-range color.
- D22 Studio Daylight: Contains twenty-two 5600 K LEDs for high-intensity, non-variable cool-white output
- D22 Studio Tungsten: Contains twenty-two 3000 K LEDs for high-intensity, non-variable warm-white output
- D22 Studio HD: Combines warm white and cool white LEDs for variable-color-temperature mixing. Added to this are carefully chosen colors from the Selador x7 Color System to fill in the white LED spectral gaps, providing the richest variable-white light possible in an LED fixture

**D22 Mounting Configurations**

D22 fixtures are available in three different mounting options to fit any installation:

- D22 Portable: Standard yoke-mount hardware; power lead with Edison/Schuko/UK13A connector and DMX in/thru connectors
- D22 Install Canopy: Standard yoke-mount and canopy hardware; power lead with bare ends; and a permanent, single DMX in/thru cable
- D22 Track-Yoke: One Track or DataTrack adapter and a single, permanent cable for both power and DMX in

**ORDERING INFORMATION**

**Selador D22**

MODEL	DESCRIPTION	ETL PART NUMBERS	CE PART NUMBERS	
SELD22L	D22 Lustr+ wash fixture	7411A1050-0A (Edison)	7411A1250-0S (Schuko) 7411A1250-0U (UK13A)	
SELD22D	D22 Studio Daylight wash fixture	7411A1070-0A (Edison)	7411A1270-0S (Schuko) 7411A1270-0U (UK13A)	
SELD22T	D22 Studio Tungsten wash fixture	7411A1060-0A (Edison)	7411A1260-0S (Schuko) 7411A1260-0U (UK13A)	
SELD22H	D22 Studio HD wash fixture	7411A1020-0A (Edison)	7411A1220-0S (Schuko) 7411A1220-0U (UK13A)	

Color options: -1 = white, -5 = silver

Note: D22 luminaires ship with hanging yoke. See page 8 for connector options. C-clamps are not included.



## PRODUCT SPECIFICATIONS

## Source

LED details	22 Lumileds LUXEON® Rebel LED
Max lumens	Lustr+: 1,499 Studio Daylight: 2,533 Studio Tungsten: 2,096 Studio HD: 1,247
Lumens per watt	Lustr+: 31 Studio Daylight: 50 Studio Tungsten: 41 Studio HD: 31
L70 rating (hours to 70% output)	50,000 hours

## Color

Colors used	Lustr+: Red, Amber, Green, Cyan, Blue, Indigo, White Vivid: Red, Red-Orange, Amber, Green, Cyan, Blue, Indigo Studio HD: Red, Amber, Green/Cyan, Blue, Warm White, Cool White Studio Daylight: White Studio Tungsten: White
Color temperature range	2,700–6,500 K
Calibrated array	Lustr+: Yes Studio Daylight: No Studio Tungsten: No Studio HD: Yes
Red shift	Yes

## Optical

Beam angle	8°–71°
Aperture size	6 in
Pattern projection	No
Camera flicker control/Hz range	Yes: 900–25,000 Hz
Notes	Secondary lenses available for multiple beam-spread options

## Control

Input method	DMX512 via 5-pin XLR (portable only) Permanent power input cable
Protocols	DMX-512/RDM
Modes (footprint)	See page 5
RDM configuration	Yes
UI type	LCD
Local control	Yes
Onboard presets	Yes
Onboard sequences	Yes
Onboard effects	No
Fixture-to-fixture control	Yes
Notes	15-bit virtual dimming engine

## Control

Fixture-to-fixture control	Yes
Notes	15-bit virtual dimming engine

## Electrical

Voltage range	100–240 VAC 50/60 Hz
Input method	Requires power from a non-dimmable source Portable: Edison, Schuko or UK13A connector
Inrush (over first half-cycle)	17 A at 120 V 25 A at 240 V
Fixtures per circuit*	20 (R20 module or similar)
Wattage typical	56.5
Current draw	0.58 A at 110 V 0.48 A at 120 V 0.29 A at 230 V 0.29 A at 240 V

\*All measurements are for 120 V, 60 Hz. Results may vary in different regions.

## Thermal

Ambient operating temp	0°–40° C (32°–104° F)
Fan (controllable)	No
Droop compensation	Yes
dB range	N/A
BTUs/hour	192.778

## Physical

Materials	Die-cast, all metal housing
Color options	Black, white, silver, or custom color
Mounting options	Portable, install canopy, or track-yoke
IP rating	IP20 for portable and canopy versions IP40 for track version
Weight	3.13 kg (6.9 lb)
Included accessories	Hanging yoke

## Warranty

Fixture	5 years
LED array	10 years

## Regulatory and Compliance

Approved regulatory standards	UL 1573 CSA C22.2 No. 166 CE Compliant EAC Compliant
-------------------------------	---

ETC utilizes a nationally recognized 3rd party lab for luminaire testing according to IES LM-84. See [etcconnect.com/About/News/ETC-Fixture-Ratings-and-Warranties-Extended.aspx](http://etcconnect.com/About/News/ETC-Fixture-Ratings-and-Warranties-Extended.aspx).

All LED sources experience some lessening of light output and some color shift over time. LED output will vary with thermal conditions. In individual situations, LEDs will be used for different durations and levels. This can eventually lead to minor alterations in color performance, necessitating slight adjustments to presets, cues or programs.

PRODUCT FEATURES



**MULTIPLE LED ARRAY OPTIONS**

Available in both colored and white arrays, making D22 ideal for any installation.



**EXCLUSIVE X7 COLOR SYSTEM**

Provides a full gamut of color options for every design.



**NOISELESS, FAN-FREE**

Convection cooling for acoustically sensitive installations

COLOR METRIC INFORMATION

D22 LUSTR+ 3200 K TM-30-18

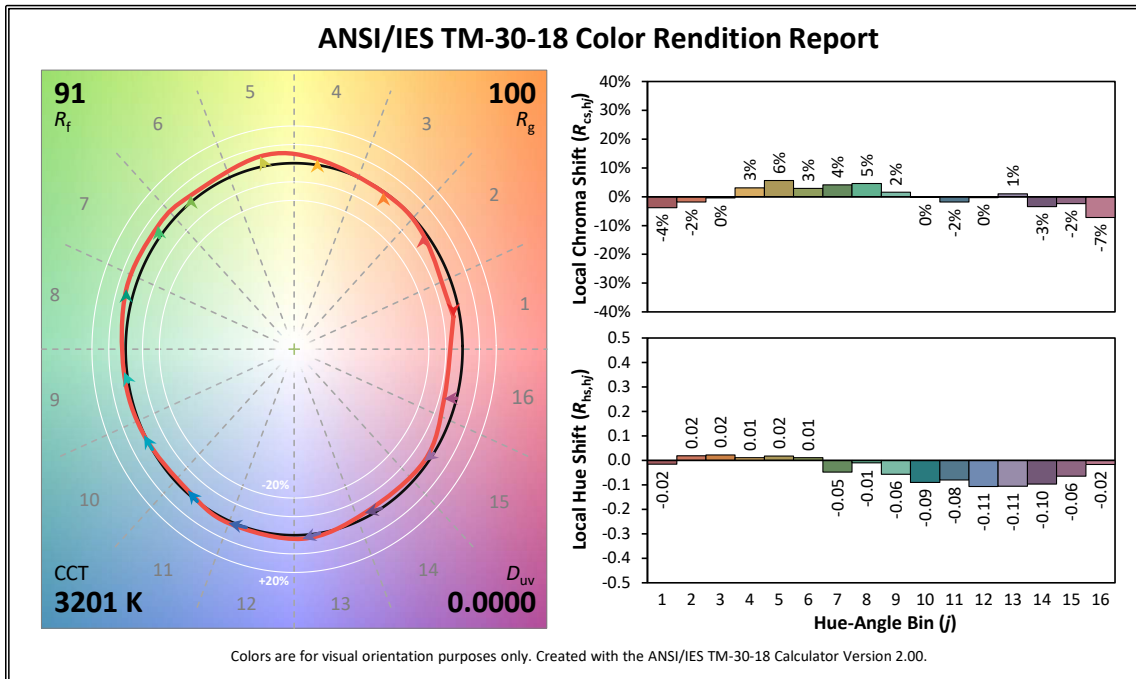

COLOR METRIC INFORMATION

D22 LUSTR+ 4500 K TM-30-18

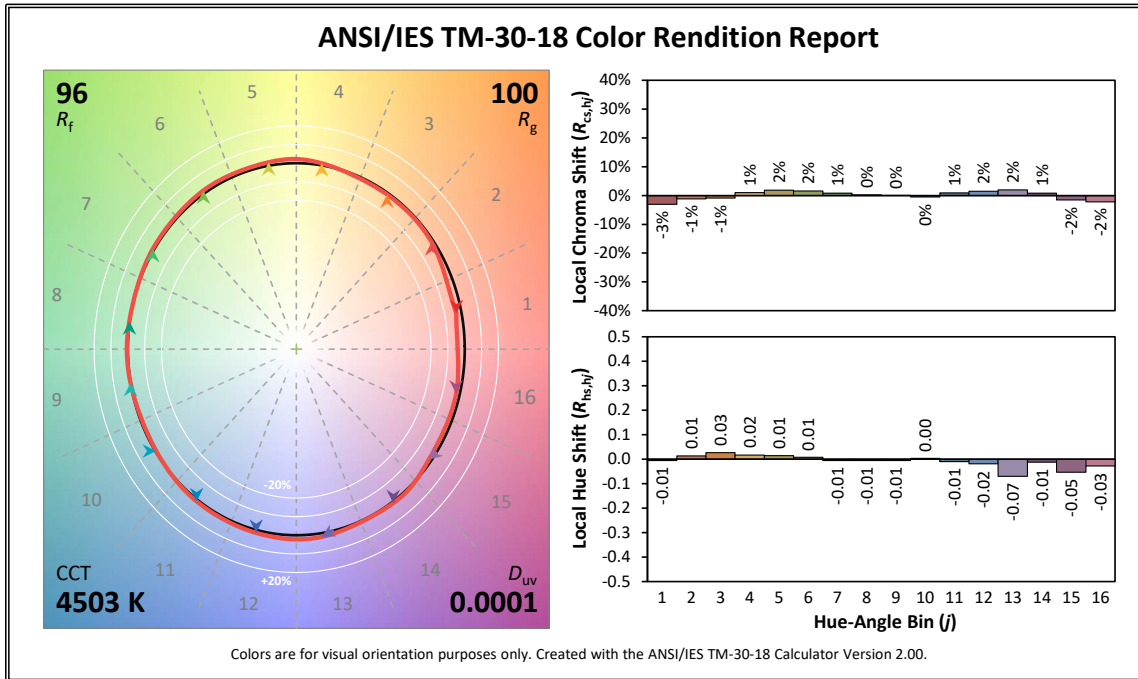

D22 LUSTR+ 5600 K TM-30-18

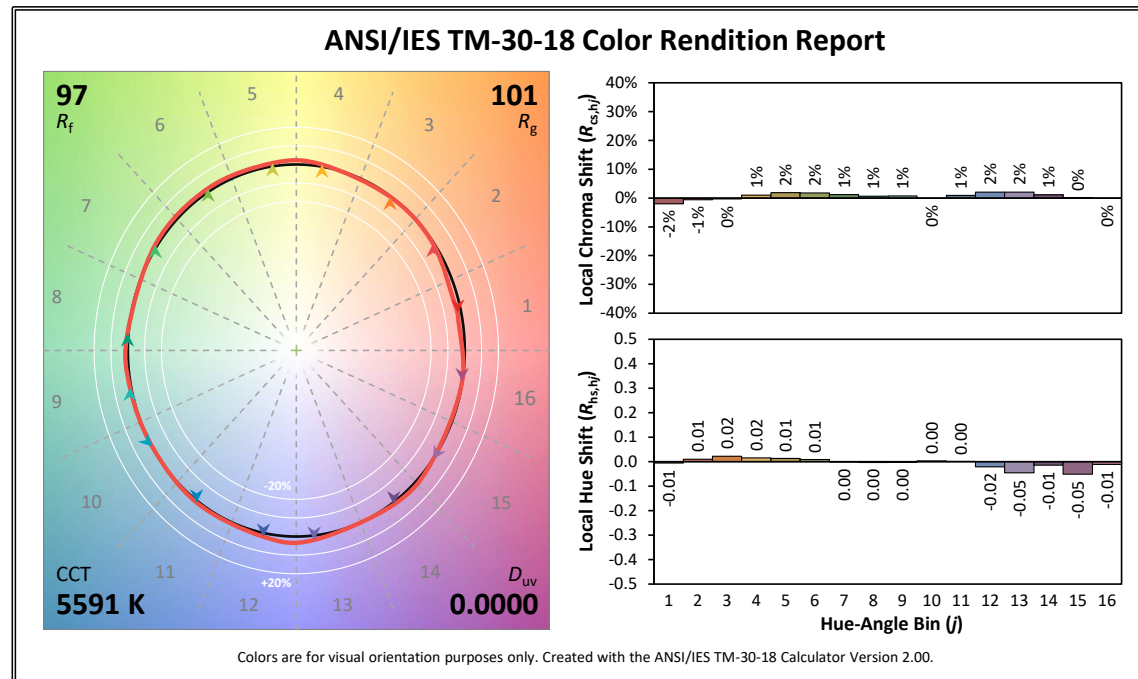

COLOR METRIC INFORMATION

D22 STUDIO HD 3200 K TM-30-18

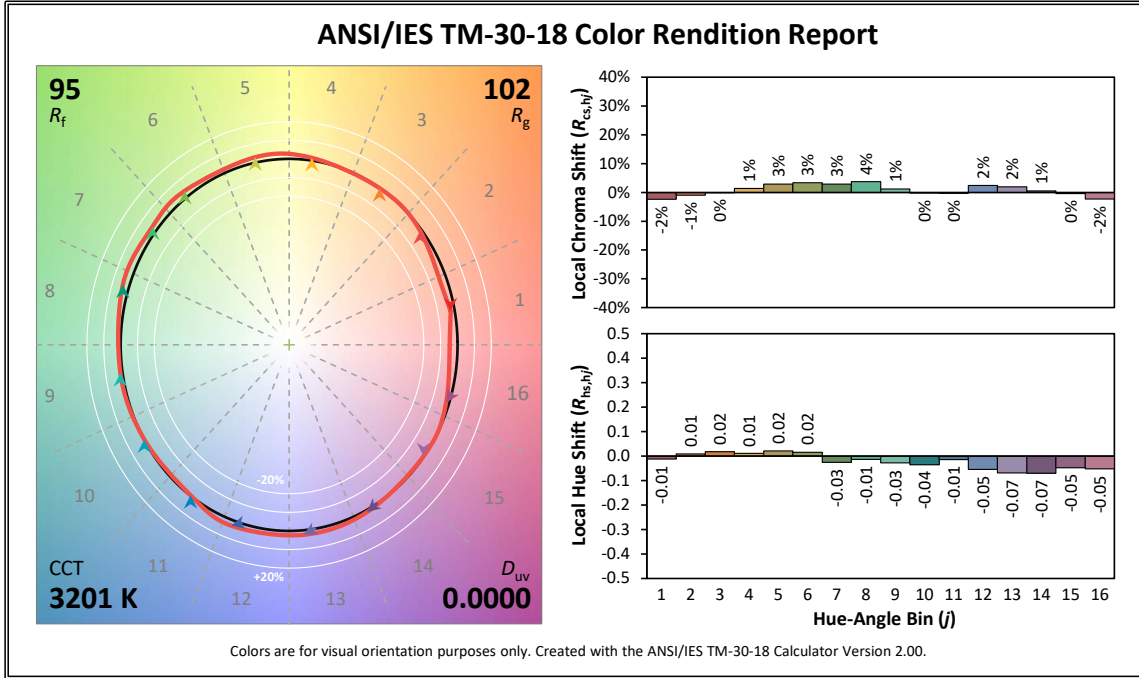

D22 STUDIO HD 4500 K TM-30-18

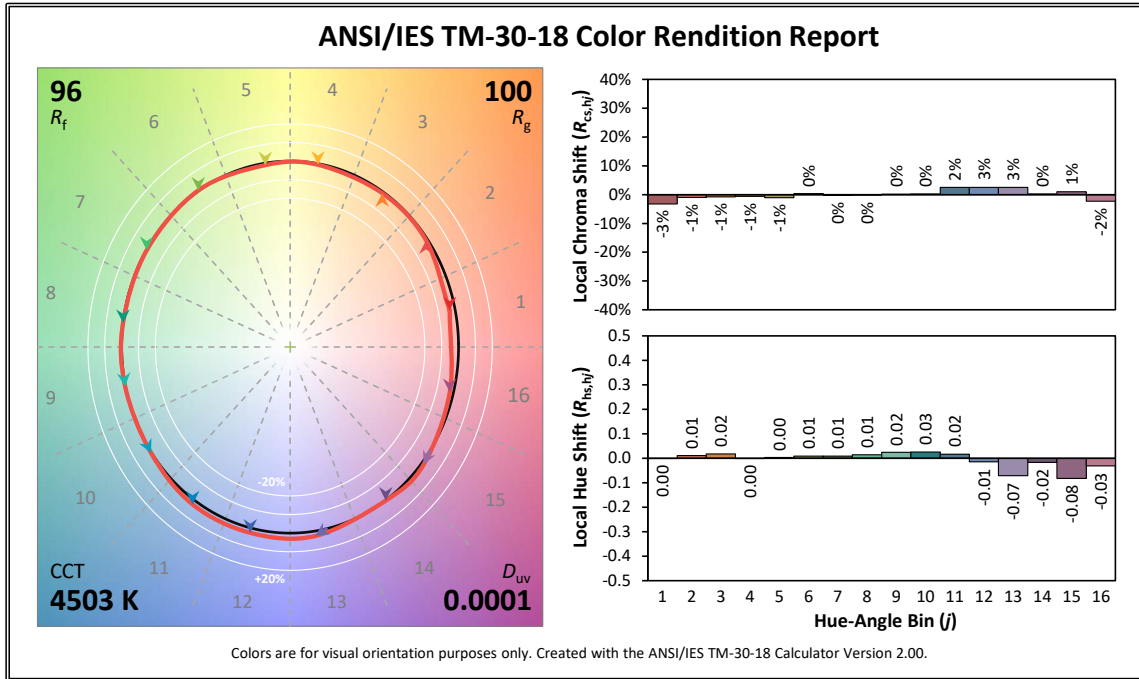

COLOR METRIC INFORMATION

D22 STUDIO HD 5600 K TM-30-18

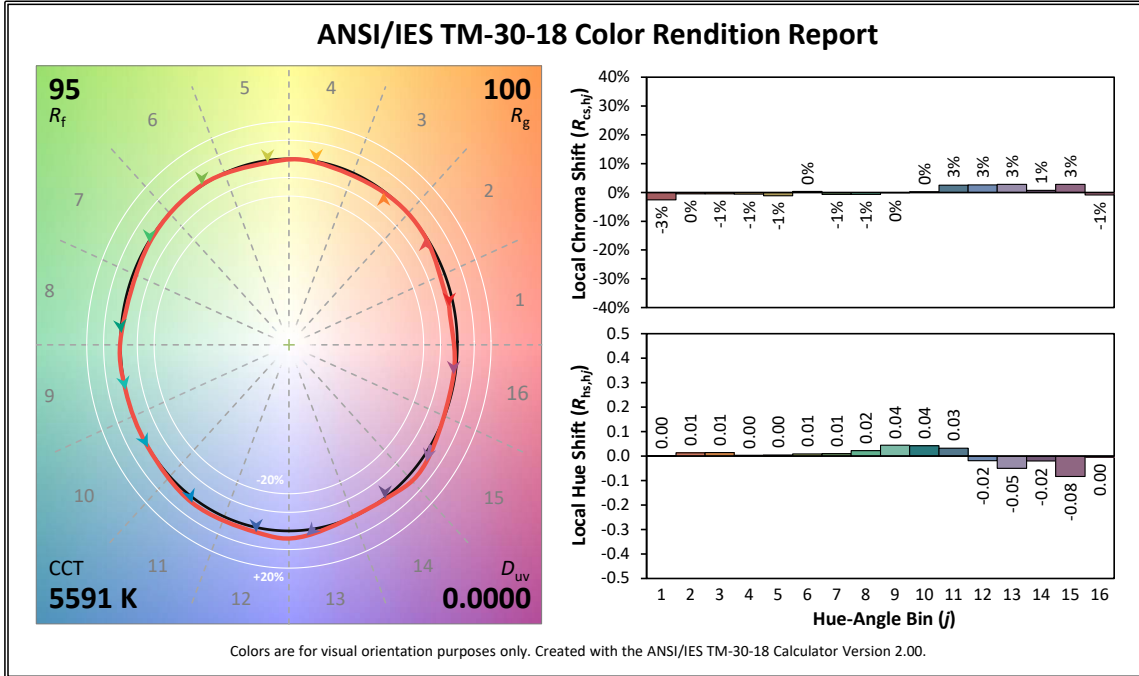

ADDITIONAL ORDERING INFORMATION

**Secondary Lens Options**

The following lenses are cut for D22 fixtures and create round, linear or oblong field patterns as described below. These lenses are not sized for use in Selador Classic (Vivid-R, Lustr, etc.) fixtures.

Note: This is the same material as Selador Classic lenses.

MODEL	DESCRIPTION	PART NUMBER	
<b>Narrow Linear Field</b>	Linear lenses may be combined to create desired field size, i.e. 40° X 60°		
SELLN-D22	Narrow lens (narrow linear field)	7411K1010	
SELLM-D22	Medium lens (narrow linear field)	7411K1011	
SELLW-D22	Wide lens (narrow linear field)	7411K1012	
SELLXW-D22	Extra wide lens (narrow linear field)	7411K1013	
<b>Round Field</b>			
SELRN-D22	Narrow lens (round field)	7411K1002	
SELRM-D22	Medium lens (round field)	7411K1003	
SELRW-D22	Wide lens (round field)	7411K1004	
SELRXW-D22	Extra wide lens (round field)	7411K1005	
<b>Oblong Field</b>			
SELON-D22	Narrow lens (oblong field)	7411K1006	
SELOM-D22	Medium lens (oblong field)	7411K1007	
SELOW-D22	Wide lens (oblong field)	7411K1008	

[Desire lenses compared to Source Four PAR EA](#)

**Typical Lens-Field Profiles**

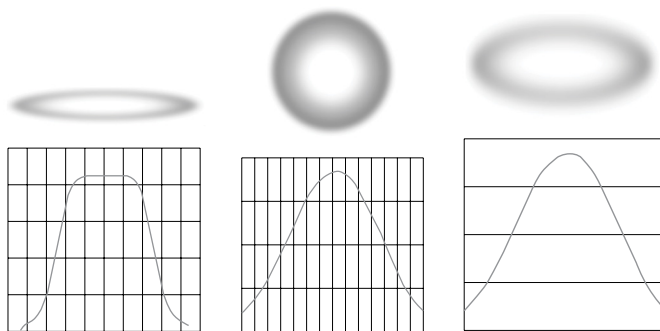

Narrow Linear

Round

Oblong

---

**ADDITIONAL ORDERING INFORMATION**
**Connector Options**

Use information below to order input with factory-fitted connectors

MODEL	DESCRIPTION
n/a	Portable with Edison connector
-I	Install canopy mounting
-OT	OneTrack mounting adaptor
-T	DataTrack mounting adaptor

**Fixture Accessories**

MODEL	DESCRIPTION	PART NUMBER
SELD22BD	Barn door (Use only as a flexible top hat to diminish aperture glare. Not for beam shaping.)	PSF1113
SELD22CF	5.5 in Color frame (use for round and oblong lenses)	PSF1114
SELD22ECL	Egg crate louver	PSF1111
SELD22HS	Half-shield	PSF1112
SELD22FSY	Yoke with floor stand attachment	7411K1016
400CC	C-clamp (does not ship with fixture)	7060A2009 (not CE)
400SC	Safety cable (32 in)	7060A1022

Note: All model numbers above are for black accessories. Add -1 for white or -5 for silver. Custom colors are available upon request.



**CONTROL OPTIONS**

User settings on D22 fixtures allow multiple operational modes and settings for either console operation via DMX protocol or stand-alone operation. The expanded LCD display provides easy navigation to all possible settings and options. Some of them are:

- Multiple DMX choices, ranging from a simple RGB profile – which effectively controls all seven LED colors via three channels – to nine-channel ‘direct’ color and intensity control
- Multiple dimming curve options
- Preset colors and sequences for stand-alone (no console required) operation
- White-point selection: White-light and color behavior based on a specific-color-temperature white light, i.e., 3200 K, 5600 K, etc.
- Loss of data behavior options: Instant off, hold last look for two minutes, etc.
- Output modes: Three output options that offer the user a choice between maximum output and maximum consistency

See the user manual for a complete explanation of all of the control settings and options for the D22.

**Quick Setups**

Use one of five Quick Setups on the fixture display to get started. You can modify the setting as needed.

Setting Title	Profile	Description	Typical Features*
General	Direct	Factory default: For general-purpose use, including interior architectural applications	<ul style="list-style-type: none"> <li>• Standard dimming curve</li> <li>• Regulated output for color consistency</li> </ul>
Stage	HSI Plus 7 Enabled	Theatrical lighting: Duplicates the color and dimming behavior of tungsten stage lighting fixtures	<ul style="list-style-type: none"> <li>• Incandescent dimming curve</li> <li>• Regulated output for color consistency</li> <li>• 3250 K white-point setting</li> </ul>
XT Arch	HSI	Exterior architectural lighting: Provides a high degree of color consistency in high ambient-temperature environments	<ul style="list-style-type: none"> <li>• Standard dimming curve</li> <li>• Protected output</li> <li>• 3200 K white-point setting</li> </ul>
High Impact	RGB	Event lighting: Enables quickest response, simple RGB control and strobe channel for maximum effect usage	<ul style="list-style-type: none"> <li>• Quick dimming curve</li> <li>• Boost mode for maximum intensity</li> <li>• 5600 K white-point setting</li> </ul>
Studio	Studio	Studio factory default: Enables three-parameter control of white light (intensity, white point, and tint) via DMX from a console or from the fixture display – without a console	<ul style="list-style-type: none"> <li>• Linear dimming curve</li> <li>• Regulated output mode for color consistency</li> </ul>

\*See user manual for complete list of features for each Quick Setup

**CONTROL OPTIONS**

**DMX Input Channel Profiles**

DMX Profile	DMX Channels	Channel Assignments	Notes
Direct	9	1 – Red 2 – White 3 – Amber 4 – Green 5 – Cyan 6 – Blue 7 – Indigo 8 – Intensity 9 – Strobe	Direct control of each individual color with a separate master-intensity channel. Color calibration of LEDs is not active in this mode. The nine-channel profile will produce the highest-quality color crossfades.
HSI	5	1 – Hue (coarse) 2 – Hue (fine) 3 – Saturation 4 – Intensity 5 – Strobe	High-resolution hue (two channels), saturation, and intensity control. HSI mode will produce arbitrary color crossfades around the color space.
HSIC	6	1 – Hue (coarse) 2 – Hue (fine) 3 – Saturation 4 – Intensity 5 – Strobe 6 – Color Point (CCT)	High-resolution hue, saturation and intensity control as above, with the addition of a color-point channel to adjust the color temperature of the fixture in both white light and color. Color crossfade performance is the same as HSI.
RGB	5 (Ch. 4 not used)	1 – Red 2 – Green 3 – Blue 4 – n/a 5 – Strobe	Effectively addresses all seven colors via three channels of control. RGB profile will produce medium-quality color crossfades
Studio	3	1 – Intensity 2 – Color Point (CCT) 3 – Tint	Controls fixture as a white-light unit. If for example, no DMX console input is present, the fixture can be adjusted for these three parameters on the UI at the back of the unit.
Additional profile options			
Plus 7		Seven additional color-control channels are available in RGB, HSI, HSIC, and Studio profile settings. For example, HSI with ‘Plus 7’ enabled becomes a 14-channel profile:	
		1 – Hue (coarse) 2 – Hue (fine) 3 – Saturation 4 – Intensity 5 – Strobe 6 – n/a 7 – Plus 7 Control on/off 8 – Red 9 – Orange (white for Lustr+) 10 – Amber 11 – Green 12 – Cyan 13 – Blue 14 – Indigo	The desired color and intensity is achieved by using the HSI or RGB channels.  Placing channel seven at a value over 51% gives the fixture a 14-channel profile.  Channels 8–14 represent the native colors of the fixture and allow the operator to adjust individual color channels to fine tune the color output.
Strobe		Variable strobe control: 0% is no strobe. The fixture output will strobe more rapidly as the strobe channel value approaches 100%.	

## CONTROL OPTIONS

## Studio Daylight and Studio Tungsten (only)

## Quick Set-Ups

Setting Title	Profile	Description	Typical Features
Studio	Studio	Enables control of intensity from luminaire UI; no console required	<ul style="list-style-type: none"> <li>• Linear dimming curve</li> <li>• Regulated output for intensity stability</li> </ul>
Single Channel	Direct	For general purpose architectural use	<ul style="list-style-type: none"> <li>• Standard dimming curve</li> <li>• Regulated output for color consistency</li> </ul>
Stage	Direct	Matches conventional luminaire performance	<ul style="list-style-type: none"> <li>• Incandescent dimming curve</li> <li>• Regulated output</li> </ul>

## DMX Input Channel Profiles

DMX Profile	DMX Channels	Channel Assignments	Notes
Studio	3	1 – Intensity 2 – Strobe 3 – Fan Control	Control parameters is from the luminaire's user interface. No console required.
Direct	3	1 – Intensity 2 – Strobe 3 – Fan Control	

## LENS INFORMATION

## Desire diffusion angle measurements

NOMINAL									
	No Lens	Very Narrow	Narrow	Medium	Wide	Extra Wide	Narrow Oval	Medium Oval	Wide Oval
		25°	35°	45°	75°	N/A	20° x 40°	30° x 70°	35° x 80°
<b>D22</b>									
<b>LUSTR+</b>	21	24	30	49	83	108	23 x 45	29 x 55	35 x 68
<b>STUDIO HD</b>	24	26	33	51	86	110	21 x 42	34 x 60	55 x 87
<b>STUDIO D</b>	23	30	32	50	83	107	24 x 47	30 x 57	51 x 80
<b>STUDIO T</b>	25	28	31	49	82	106	24 x 47	29 x 56	37 x 70

Values in black refer to old lens descriptions.

PHOTOMETRICS

D22 Lustr+

Mode	Degree	Candela	Field Lumens	Beam Lumens	Lumens Per Watt
Boost - Cold	21°	48,900	1,658	682	31.5
Regulated	21°	43,400	1,479	608	30.5

Metric conversions: For meters, multiply feet by 0.3048.  
For lux, multiply foot-candles by 10.76.

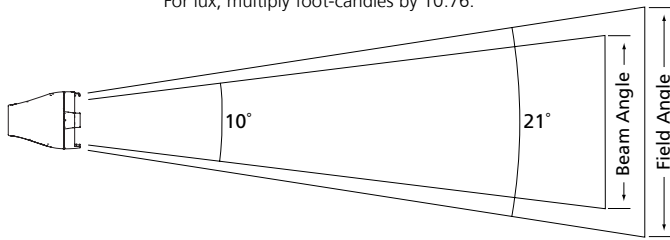

Throw Distance (d)	10 ft	15 ft	20 ft	30 ft	208.3 ft
	3.0 m	4.6 m	6.1 m	9.1 m	63.5 m
Field Diameter	3.7 ft	5.6 ft	7.5 ft	9.4 ft	78.0 ft
	1.1 m	1.7 m	2.3 m	2.9 m	23.8 m
Illuminance (fc)	434	193	109	69	
Illuminance (lux)	4,672	2,076	1,168	747	

To determine center beam illumination in foot-candles at any throw distance, divide candela by the throw distance squared.

For field diameter at any distance, multiply distance by 0.374.  
For beam diameter at any distance, multiply by 0.168.

D22 Studio Daylight

Mode	Degree	Candela	Field Lumens	Beam Lumens	Lumens Per Watt
Boost - Cold	23°	74,986	3,029	1,393	46.2
Regulated	23°	69,480	2,883	1,367	46.5

Metric Conversions: For meters, multiply feet by .3048.  
For lux, multiply foot-candles by 10.76.

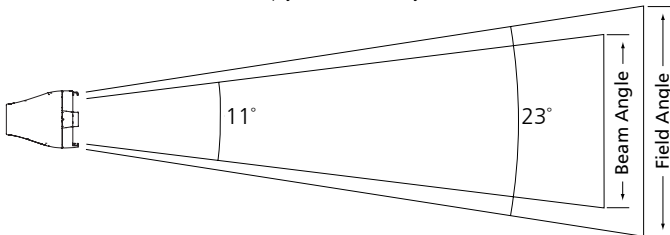

Throw Distance (d)	10 ft	15 ft	20 ft	25.0 ft	263.6 ft
	3.0 m	4.6 m	6.1 m	7.6 m	80.3 m
Field Diameter	4.1 ft	6.1 ft	8.1 ft	10.1 ft	106.8 ft
	1.2 m	1.9 m	2.5 m	3.1 m	32.5 m
Illuminance (fc)	695	309	174	111	
Illuminance (lux)	7,479	3,324	1,870	1,197	

To determine center beam illumination in foot-candles at any throw distance, divide candela by the throw distance squared.

For field diameter at any distance, multiply distance by 0.405.  
For beam diameter at any distance, multiply by 0.191.

Cosine Candela Plot

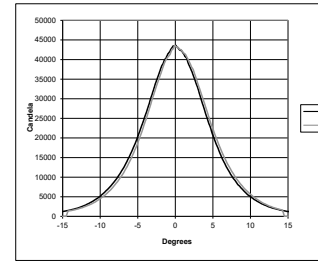

Iso-Illuminance Diagram (Flat Surface Distribution)

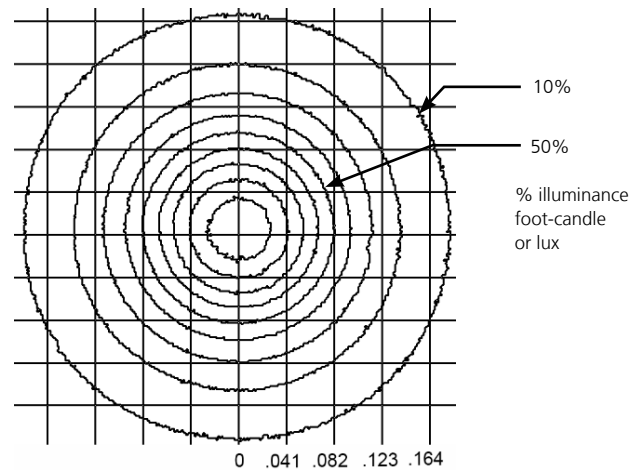

Cosine Candela Plot

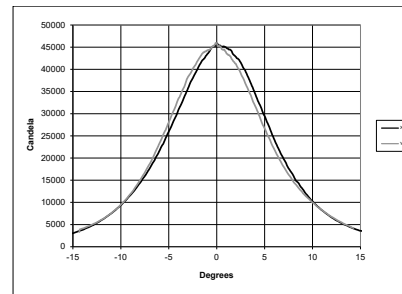

Iso-Illuminance Diagram (Flat Surface Distribution)

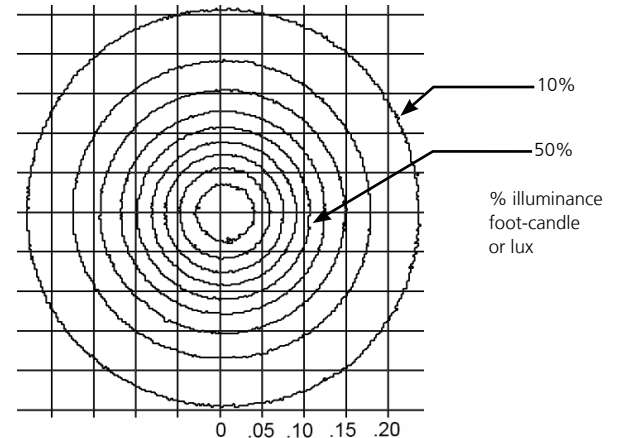

PHOTOMETRICS

D22 Tungsten

Mode	Degree	Candela	Field Lumens	Beam Lumens	Lumens Per Watt
Boost - Cold	26°	41,660	2,177	994	40.8
Regulated	26°	39,500	2,064	944	40.5

Metric conversions: For meters, multiply feet by 0.3048.  
For lux, multiply foot-candles by 10.76.

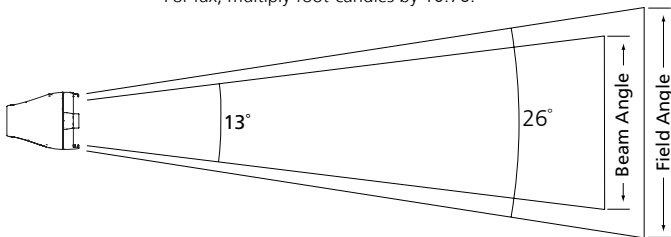

Throw Distance (d)	10 ft 3.0 m	15 ft 4.6 m	20 ft 6.1 m	25 ft 7.6 m	198.7 ft 60.6 m
Field Diameter	4.5 ft 1.4 m	6.8 ft 2.1 m	9.0 ft 2.7 m	11.3 ft 3.4 m	89.6 ft 27.3 m
Illuminance (fc)	395	176	99	63	
Illuminance (lux)	4,252	1,890	1,063	680	

To determine center beam illumination in foot-candles at any throw distance, divide candela by the throw distance squared.

For field diameter at any distance, multiply distance by 0.451.  
For beam diameter at any distance, multiply by 0.219.

D22 Studio HD

Mode	Degree	Candela	Field Lumens	Beam Lumens	Lumens Per Watt
Boost - Cold	24°	43,370	1,887	793	35.3
Regulated	24°	41,860	1,829	773	35.6

Metric conversions: For meters, multiply feet by 0.3048.  
For lux, multiply foot-candles by 10.76.

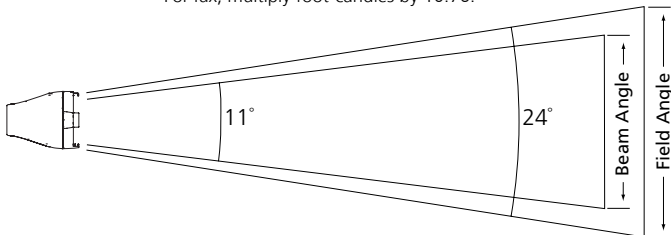

Throw Distance (d)	10 ft 3.0 m	15 ft 4.6 m	20 ft 6.1 m	25 ft 7.6 m	204.6 ft 62.4 m
Field Diameter	4.2 ft 1.3 m	6.3 ft 1.9 m	8.4 ft 2.6 m	10.5 ft 3.2 m	86.2 ft 26.3 m
Illuminance (fc)	419	186	105	67	
Illuminance (lux)	4,506	2,003	1,126	721	

To determine center beam illumination in foot-candles at any throw distance, divide candela by the throw distance squared.

For field diameter at any distance, multiply distance by 0.421.  
For beam diameter at any distance, multiply by 0.191.

Cosine Candela Plot

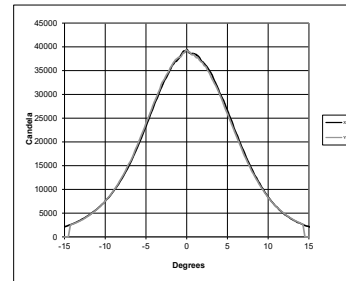

Iso-Illuminance Diagram (Flat Surface Distribution)

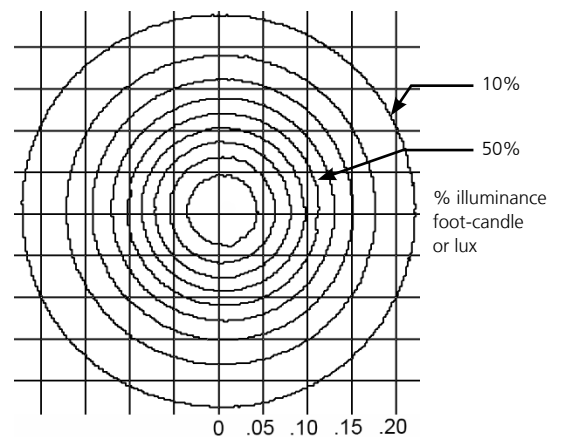

Cosine Candela Plot

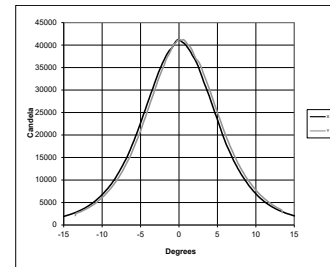

Iso-Illuminance Diagram (Flat Surface Distribution)

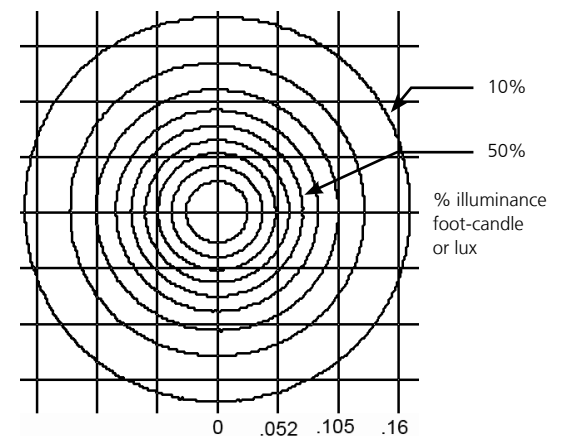

PHYSICAL

Selador D22 Weights and Dimensions

WEIGHT*		SHIPPING WEIGHT	
lb	kg	lb	kg
6.9	3.13	8.5	3.86

\* Does not include mounting hardware

CANOPY

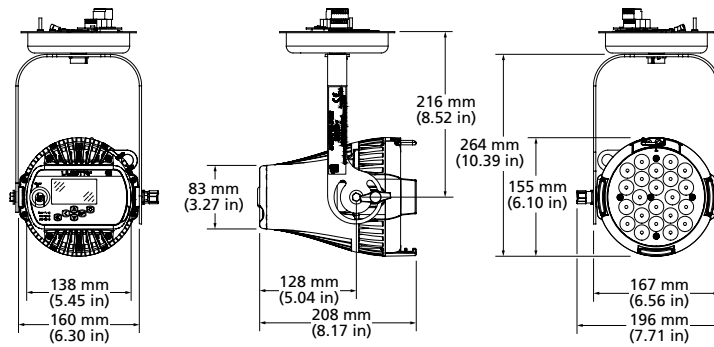

PORTABLE

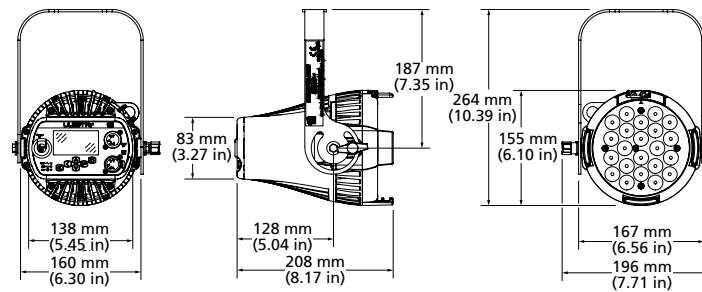

DATATRACK

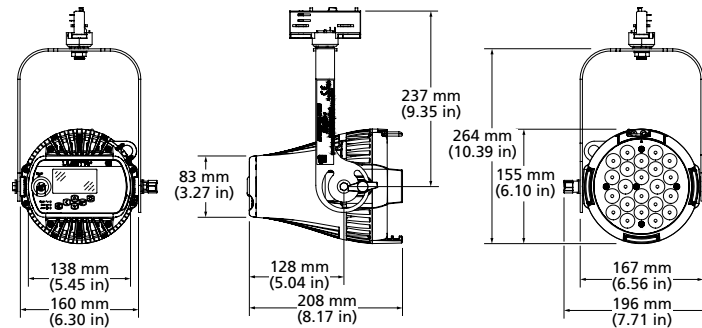

Corporate Headquarters • Middleton, WI USA  
 Global Offices • London, UK • Rome, IT • Holzkirchen, DE • Paris, FR • Hong Kong  
 Dubai, UAE • Singapore • New York, NY • Orlando, FL • Los Angeles, CA • Austin, TX  
 ©2024 ETC. All Rights Reserved. All product information and specifications subject to change. Rev L 2024-02  
 \*Trademark and patent info: [etconnect.com/IP](http://etconnect.com/IP) • Third-party license agreement info: [etconnect.com/licenses](http://etconnect.com/licenses)