



Type(s)
Project
Date
Notes

GENERAL INFORMATION

An LED luminaire crafted by lighting experts with a proven history of quality spot fixtures, ColorSource Spot V brings a richness of color, increased brightness, and leading technology at a price point you'll love. Featuring a five-color array of red, green, blue, indigo, and lime, the ColorSource Spot V provides soft pastels and bold saturated colors from a single fixture. Featuring wireless DMX/RDM control using Multiverse® technology, NFC configuration from your mobile device, and next level brightness, ColorSource Spot V is the ultimate in versatility.

APPLICATIONS

- Theatres and performance spaces
- Houses of worship
- Universities and schools
- Hospitality
- Retail
- Exhibition centers
- Meeting rooms
- Clubs
- Cafeteriums

PRODUCT FEATURES

- Five-color array (red, green, blue, indigo, and lime)
- Simple user interface with seven-segment display
- powerCON® TRUE1® TOP connector
- DMX/RDM in and thru (5-pin XLR)
- Multiverse wireless DMX/RDM
- NFC (near field communication) configuration
- LED droop compensation
- Optically calibrated
- Tour-ready, aluminum housing
- Combine with available adapters to transform your fixture into a fully functional Fresnel or CYC light

ORDERING INFORMATION

ColorSource Spot V Light Engine with Shutter Barrel

(For use with fixed-field lens tubes only)

MODEL	DESCRIPTION	ETL PART NUMBER	CE PART NUMBER
CSSPOTVMVS	ColorSource Spot V with Multiverse, with shutter barrel, black	7423A1011	7423A1211

ColorSource Spot V Light Engine Body

(For use with zoom lens tubes and adapters and for retrofit of existing fixtures)

MODEL	DESCRIPTION	ETL PART NUMBER	CE PART NUMBER
CSSPOTVMV	ColorSource Spot V with Multiverse, body only, black	7423A1010	7423A1210

Color options: -1 = white, -5 = silver gray, -8 = custom colors.

Also available without Multiverse wireless control. Contact your dealer for ordering information.

Fixture ships with a soft-focus diffuser in a gobo holder, and a 1.5 m powerCON TRUE1 TOP power-input cable with a connector of choice. See page 5 for connector options.

Please note: Lens tubes and c-clamp to be ordered separately.



PRODUCT SPECIFICATIONS

Source

LED details	60 Lumileds LUXEON® C and LUXEON Rebel LEDs
Max lumens	9,498
Lumens per watt	48
L70 rating (hours to 70% output)*	54,000 hours

Color

Colors used	Red, green, blue, indigo, lime
Color temperature range	Color mixing
Calibrated array	Yes
Red shift	No

Optical

Beam angle range	Swappable lens tubes, 5–90 degrees
Gate size	80 mm
Aperture size	6.25–14 in (depending on lens tube)
Pattern projection	Yes
Pattern size	A or B
Camera flicker control/Hz range	5,000 Hz (default) and 25,000 Hz (via RDM)
Notes	Can be used with LED CYC and Fresnel adapters

Control

Input method	DMX512 via 5-pin XLR connector
Protocols	DMX512/RDM
Modes (footprint)	5 modes, see page 4
RDM configuration	Yes
UI type	Seven-segment, three-button interface
Local control	Yes
Onboard presets	Yes (12)
Onboard sequences	Yes (5)
Onboard effects	No
FixtureLink	Yes
Notes	15-bit virtual dimming engine

Wireless

Band	2.400–2.480 GHz
Range	100 m indoors, 500 m line of sight (subject to conditions)
Max receivers	DMX: No limit RDM: Varies by transmitter used Multiverse SHoW Baby®: 585 Multiverse Transmitter: 5,000
Broadcast power	100 mW

Electrical

Voltage range	100–240 VAC 50/60 Hz
Input method	powerCON TRUE1 TOP power in and thru
Inrush	55 A at 120 V (First half-cycle) 59 A at 240 V (First half-cycle)
Fixtures per circuit*	8 fixtures (R20 module or similar)
Wattage typical / standby	199 W / 2 W at 100 V 197 W / 2 W at 120 V 194 W / 2 W at 240 V
Current draw typical / standby	2 A / 0.07 A at 100 V 1.65 A / 0.08 A at 120 V 0.90 A / 0.10 A at 240 V

*Note: All measurements are for 120 V, 60 Hz. Results may vary in different regions.

Thermal

Ambient operating temp	0°C to 40°C (32°F to 104°F)
Fan (controllable)	Yes (yes)
Droop compensation	Yes
dB range	24.4 dBA average at 1 m
BTUs/hour	672

Physical

Materials	Die-cast, all metal housing
Color options	Black, white, silver, or custom color
Mounting options	Yoke
IP rating	IP20
Weight	7.7 kg (17 lb) (without lens)
Included accessories	Hanging yoke, 1.5 m power cable, soft-focus diffuser in an A-size gobo holder
Notes	See page 5 for power cable options

Warranty

Fixture	5 years
LED array	10 years

Regulatory and Compliance

Approved regulatory standards	cETLus Listed Conforms to UL 1598 Listed Conforms to UL 924 Listed Certified to CSA C22.2 No. 250 Listed Certified to CSA C22.2 No. 141 Listed CE, UKCA, RCM, and CCC Compliant
-------------------------------	--

All LED sources experience some lessening of light output and some color shift over time. LED output will vary with thermal conditions. In individual situations, LEDs will be used for different durations and levels. This can eventually lead to minor alterations in color performance, necessitating slight adjustments to presets, cues or programs.

PRODUCT FEATURES

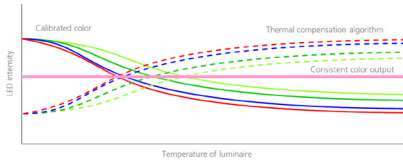

LED DROOP COMPENSATION

ETC’s custom software adjusts for the changes that naturally occur as LEDs heat up and cool down so you never have to worry about color shift.



RGBIL ARRAY

The custom five-color blend of LEDs incorporates indigo and lime to increase spectral reach and color depth.



WIRELESS

Multiverse gives you up to 10 universes of wireless DMX/RDM control. And NFC configuration is standard with ETC’s free Set Light app on your mobile device.

COLOR METRIC INFORMATION

COLORSOURCE SPOT V 3200 K TM-30-18

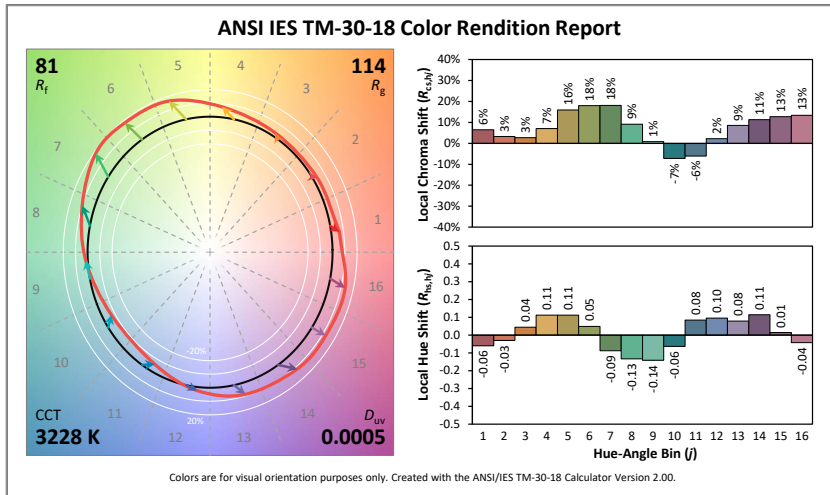

COLORSOURCE SPOT V 5600 K TM-30-18

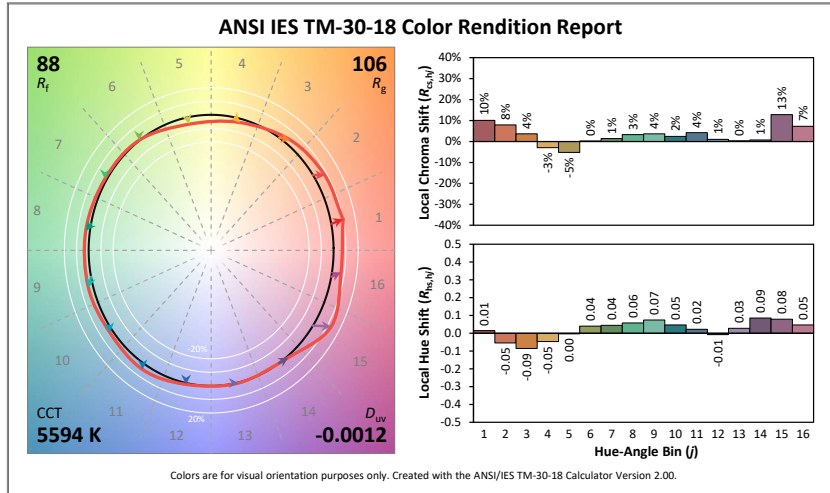

PHOTOMETRY INFORMATION

Degrees and Lumens

DEGREE	MAXIMUM OUTPUT FIELD LUMENS	DISTANCE TO ACHIEVE 50 FC
5	5906	36 m (118.1 ft)
10	5615	23.2 m (76 ft)
14	6690	16.5 m (54 ft)
19	6031	12.8 m (42 ft)
19 EDLT	6863	13.1 m (43 ft)
26	7086	10.4 m (34.1 ft)
26 EDLT	8418	11 m (36 ft)
36	7890	8.1 m (26.5 ft)
36 EDLT	8145	8.2 m (27 ft)
50	7864	6.1 m (20 ft)
50 EDLT	7980	5.8 m (18.9 ft)
70	9498	4.6 m (15 ft)
90	9360	4 m (13.1 ft)
15-30	7220	7.6 m (25 ft)
25-50	9050	11.3 m (37.2 ft)
15-30 XDLT	8754	10.3 m (33.8 ft)

The MyETC: Photometrics app provides full photometry information. For information about the Photometrics app, visit etconnect.com/Apps/.

CONTROL

DMX Input Channel Profiles

DMX PROFILE	DMX CHANNELS	CHANNEL ASSIGNMENTS	NOTES
Stn: Standard (Default mode)	6	1-Intensity 2-Red 3-Green 4-Blue 5-Strobe 6-Fan	Indigo and Lime are mixed automatically.
RGB	3	1-Red 2-Green 3-Blue	
1ch: 1-channel	1	1-Intensity	This mode controls the intensity of Preset 1.
Dir: Direct	8	1-Intensity 2-Red 3-Green 4-Blue 5-Indigo 6-Lime 7-Strobe 8-Fan	
5ch: 5-channel	5	1-Intensity 2-Red 3-Green 4-Blue 5-Strobe	This mode uses the legacy white point (5400 K) and strobe function from the original ColorSource family. Indigo and Lime are mixed automatically.

ADDITIONAL ORDERING INFORMATION

Fixture Accessories

MODEL	DESCRIPTION	PART NUMBER	
400CC	C-clamp	7060A2009 (not CE)	
400SC	Safety cable	7060A1022	
400PH-A	Pattern holder (A size) (included)	7060A1013	
400PH-B	Pattern holder (B size)	7060A1014	
400PH-G	Glass pattern holder	7060A1019	
400RS	Drop-In iris	7060A1012	
400CF	Color frame, 159 mm (6.25 in)	7060A3043	
407CF	Square color frame, 190 mm (7.5 in)	7061A3007	
400DN	Donut	7060A1015	
400TH	Top hat, 159 mm (6.25 in)	PSF1021	
400PTH6	Top hat, 191 mm (7.5 in)	PSF1023	
410TH	Top hat, 305 mm (12 in) (for 10° standard lens tubes)	PSF1024	
405TH	Top hat, 356 mm (14 in) (for 5° standard lens tubes)	PSF1025	
400HH	Half hat	PSF10216	

Power Input Cables

Use information below to order 1.5 m (5 ft) power input leads with factory-fitted connectors. CE fixtures ship with powerCON TRUE1 TOP to bare end cables in the box.

MODEL	DESCRIPTION	PART NUMBER (NOT CE)	
T1PA-A	1.5 m (5 ft) Edison plug to TRUE1 receptacle, UL 1573, black	2500B7029-A	
T1PA-B	1.5 m (5 ft) Stage Pin plug to TRUE1 receptacle, UL 1573, black	2500B7029-B	
T1PA-C	1.5 m (5 ft) Twist Lock plug to TRUE1 receptacle, UL 1573, black	2500B7029-C	
T1PA-X	1.5 m (5 ft) Bare end pigtail to TRUE1 receptacle, UL 1573, black	2500B7029-X	

Power Thru Jumpers

Note: Power thru jumpers connect to a fixture's output (thru) connector to provide a link to successive fixtures.

MODEL	DESCRIPTION	PART NUMBER	
T1PJ-5	1.5 m (5 ft) TRUE1 plug to TRUE1 receptacle fixture power jumper, UL rated, black	2500B7030	
T1PJ-10	3 m (10 ft) TRUE1 plug to TRUE1 receptacle fixture power jumper, UL rated, black	2500B7031	
DPT1A-5	1.5 m (5 ft) powerCON plug (gray) to TRUE1 receptacle adapter cable, black	2500B7038	
T1DPA-5	1.5 m (5 ft) TRUE1 plug to powerCON receptacle (blue) adapter cable, black	2500B7039	

Diffusers

The Soft Focus Diffuser fits into a standard A-size pattern holder and delivers beautiful, homogenized light. You can also use the Soft Focus Diffuser with patterns for dappled and soft-edge projections.

The Smooth Wash Diffuser is used when extra-smooth blending of multiple ColorSource Spot V luminaires is required. The smooth wash diffuser is placed into the gel-frame slot of the lens tube.

MODEL	DESCRIPTION	PART NUMBER	
S4LED-SFD	Soft Focus Diffuser (included)	7460A4019	
S4LED-SWD6	Smooth Wash Diffuser for 159 mm (6.25 in) gel frame slots	7460K1001	
S4LED-SWD7	Smooth Wash Diffuser for 190 mm (7.5 in) gel frame slots	7460K1002	
S4LED-SWD12	Smooth Wash Diffuser for 305 mm (12 in) gel frame slots (for 10° standard lens tubes)	7460K1003	
S4LED-SWD14	Smooth Wash Diffuser for 356 mm (14 in) gel frame slots (for 5° standard lens tubes)	7460K1004	

Multiverse

Model	Description	Part Number	
CT-5900	City Theatrical Multiverse SHoW Baby	4360A1091	
CT-5902	City Theatrical Multiverse Node 900 MHz / 2.4 GHz	4360A1092	
CT-5903	City Theatrical Multiverse Node 2.4 GHz	4360A1093	
CT-5910	City Theatrical Multiverse Transmitter 900 MHz / 2.4 GHz	4360A1094	
CT-5911	City Theatrical Multiverse Transmitter 2.4 GHz	4360A1095	
CT-5912	City Theatrical Multiverse Transmitter 900 MHz	4360A1096	

PREFERRED LENSING OPTIONS (Lenses sold separately)**Fixed Beam Lenses**

MODEL	DESCRIPTION	PART NUMBER	
LED50LT	LED-specific 50° EDLT lens	7460A2008	
LED50LT-1	LED-specific 50° EDLT (white) lens	7460A2008-1	
436EDLT	36° EDLT lens	7060A2048	
436EDLT-1	36° EDLT (white) lens	7060A2048-1	
426EDLT	26° EDLT lens	7060A2047	
426EDLT-1	26° EDLT (white) lens	7060A2047-1	
419EDLT	19° EDLT lens	7060A2046	
419EDLT-1	19° EDLT (white) lens	7060A2046-1	
490LT	90° lens	7060A2052-K	
490LT-1	90° (white) lens	7060A2052-1K	
470LT	70° lens	7060A2051-K	
470LT-1	70° (white) lens	7060A2051-1K	
414LT	14° lens	7060A2050-K	
414LT-1	14° (white) lens	7060A2050-1K	
410LT	10° lens	7060A2001-K	
410LT-1	10° (white) lens	7060A2001-1K	
405LT	5° lens	7060A2000-K	
405LT-1	5° (white) lens	7060A2000-1K	

Zoom Lens Assemblies

Use with light-engine body models.

MODEL	DESCRIPTION	PART NUMBER	
41530LT	Source Four 15°–30° Zoom lens	7060A2030-K	
42550LT	Source Four 25°–50° Zoom lens	7060A2032-K	
XDLT1530	XDLT 15°–30° Zoom (LED Only)	7462A2018-K	

LED Adapters

MODEL	DESCRIPTION	PART NUMBER	
S4LEDCYC	LED CYC adapter	7460A2011	
S4LEDFRES	LED Fresnel adapter	7460A2016	

PHYSICAL

ColorSource Spot V Weights

	WEIGHT*		SHIPPING WEIGHT	
	kg	lb	kg	lb
With Barrel	7.7	17.0	10.0	22.0
Without Barrel	5.9	13.0	7.4	16.3

* Does not include mounting hardware or lens tube

ColorSource Spot V Dimensions

	HEIGHT		WIDTH		DEPTH	
	mm	in	mm	in	mm	in
ColorSource Spot V	593	23.33	339	13.36	672	26.44

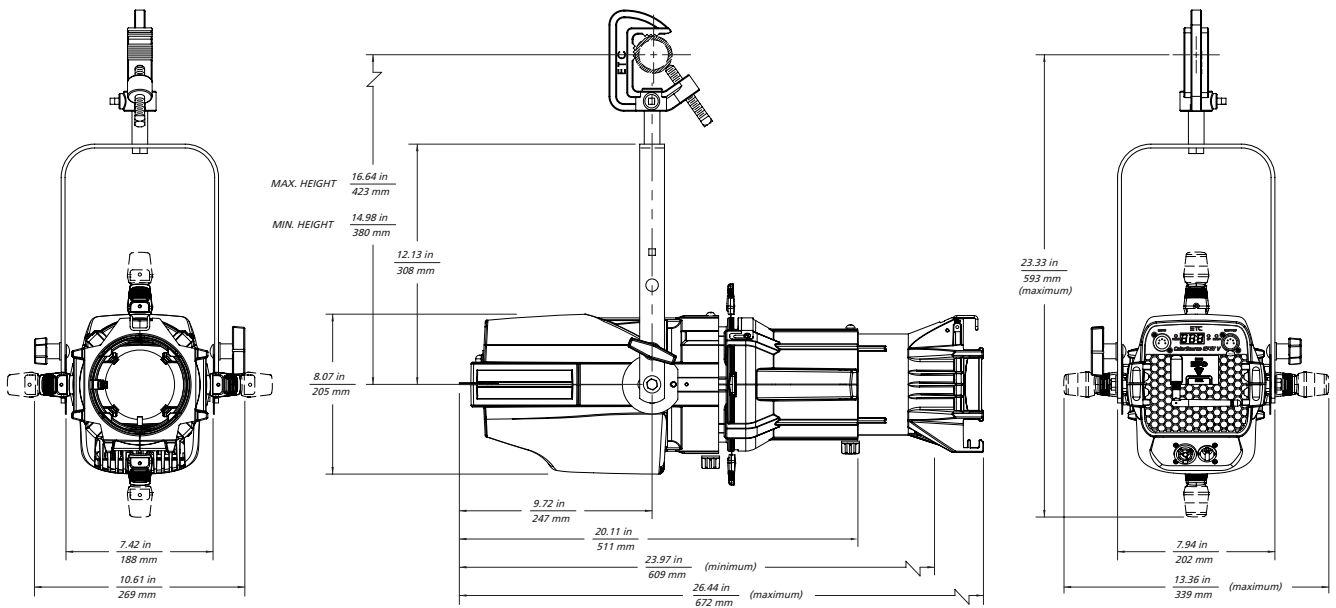

Corporate Headquarters • Middleton, WI USA
 Global Offices • London, UK • Rome, IT • Holzkirchen, DE • Paris, FR • Hong Kong
 Dubai, UAE • Singapore • New York, NY • Orlando, FL • Los Angeles, CA • Austin, TX
 ©2024 ETC. All Rights Reserved. All product information and specifications subject to change. Rev C 2024-05
 *Trademark and patent info: etconnect.com/IP • Third-party license agreement info: etconnect.com/licenses